



---

Musical Actions of Dihedral Groups

Author(s): Alissa S. Crans, Thomas M. Fiore and Ramon Satyendra

Source: *The American Mathematical Monthly*, Vol. 116, No. 6 (Jun. - Jul., 2009), pp. 479-495

Published by: [Mathematical Association of America](#)

Stable URL: <http://www.jstor.org/stable/40391142>

Accessed: 19/02/2014 05:37

---

Your use of the JSTOR archive indicates your acceptance of the Terms & Conditions of Use, available at <http://www.jstor.org/page/info/about/policies/terms.jsp>

JSTOR is a not-for-profit service that helps scholars, researchers, and students discover, use, and build upon a wide range of content in a trusted digital archive. We use information technology and tools to increase productivity and facilitate new forms of scholarship. For more information about JSTOR, please contact support@jstor.org.



*Mathematical Association of America* is collaborating with JSTOR to digitize, preserve and extend access to *The American Mathematical Monthly*.

<http://www.jstor.org>

---

# Musical Actions of Dihedral Groups

---

Alissa S. Crans, Thomas M. Fiore, and Ramon Satyendra

---

**1. INTRODUCTION.** Can you hear an action of a group? Or a centralizer? If knowledge of group structures can influence how we *see* a crystal, perhaps it can influence how we *hear* music as well. In this article we explore how music may be interpreted in terms of the group structure of the dihedral group of order 24 and its centralizer by explaining two musical actions.<sup>1</sup> The *dihedral group of order 24* is the group of symmetries of a regular 12-gon, that is, of a 12-gon with all sides of the same length and all angles of the same measure. Algebraically, the dihedral group of order 24 is the group generated by two elements,  $s$  and  $t$ , subject to the three relations

$$s^{12} = 1, \quad t^2 = 1, \quad tst = s^{-1}.$$

The first musical action of the dihedral group of order 24 we consider arises via the familiar compositional techniques of *transposition* and *inversion*. A transposition moves a sequence of pitches up or down. When singers decide to sing a song in a higher register, for example, they do this by transposing the melody. An inversion, on the other hand, reflects a melody about a fixed axis, just as the face of a clock can be reflected about the 0-6 axis. Often, musical inversion turns upward melodic motions into downward melodic motions.<sup>2</sup> One can hear both transpositions and inversions in many fugues, such as Bernstein's "Cool" fugue from *West Side Story* or in Bach's *Art of Fugue*. We will mathematically see that these musical transpositions and inversions are the symmetries of the regular 12-gon.

The second action of the dihedral group of order 24 that we explore has only come to the attention of music theorists in the past two decades. Its origins lie in the  $P$ ,  $L$ , and  $R$  operations of the 19th-century music theorist Hugo Riemann. We quickly define these operations for musical readers now, and we will give a more detailed mathematical definition in Section 5. The *parallel* operation  $P$  maps a major triad<sup>3</sup> to its parallel minor and vice versa. The *leading tone exchange* operation  $L$  takes a major triad to the minor triad obtained by lowering only the root note by a semitone. The operation  $L$  raises the fifth note of a minor triad by a semitone. The *relative* operation  $R$  maps a major triad to its relative minor, and vice versa. For example,

$$P(C\text{-major}) = c\text{-minor},$$

$$L(C\text{-major}) = e\text{-minor},$$

$$R(C\text{-major}) = a\text{-minor}.$$

It is through these three operations  $P$ ,  $L$ , and  $R$  that the dihedral group of order 24 acts on the set of major and minor triads.

The  $P$ ,  $L$ , and  $R$  operations have two beautiful geometric presentations in terms of graphs that we will explain in Section 5. Musical readers will quickly see that

---

<sup>1</sup>The composer Milton Babbitt was one of the first to use group theory to analyze music. See [1].

<sup>2</sup>A precise, general definition of inversion will be given later.

<sup>3</sup>A *triad* is a three-note chord, i.e., a set of three distinct pitch classes. *Major* and *minor* triads, also called *consonant triads*, are characterized by their interval content and will be described in Section 4.

the  $C$ -major triad shares two common tones with each of the three consonant triads  $P(C\text{-major})$ ,  $L(C\text{-major})$ , and  $R(C\text{-major})$  displayed above. These common-tone relations are geometrically presented by a toroidal graph with vertices the consonant triads and with an edge between any two vertices having two tones in common. This graph is pictured in two different ways in Figures 6 and 7. As we shall see, Beethoven's *Ninth Symphony* traces out a path on this torus.<sup>4</sup>

Another geometric presentation of the  $P$ ,  $L$ , and  $R$  operations is the *Tonnetz* graph pictured in Figure 5. It has pitch classes as vertices and decomposes the torus into triangles. The three vertices of any triangle form a consonant triad, and in this way we can represent a consonant triad by a triangle. Whenever two consonant triads share two common tones, the corresponding triangles share the edge connecting those two tones. Since the  $P$ ,  $L$ , and  $R$  operations take a consonant triad to another one with two notes in common, the  $P$ ,  $L$ , and  $R$  operations correspond to reflecting a triangle about one of its edges. The graph in Figures 6 and 7 is related to the *Tonnetz* in Figure 5: they are *dual graphs*.

In summary, we have two ways in which the dihedral group acts on the set of major and minor triads: (i) through applications of transposition and inversion to the constituent pitch classes of any triad, and (ii) through the operations  $P$ ,  $L$ , and  $R$ . Most interestingly, these two group actions are *dual* in the precise sense of David Lewin [17]. In this article we illustrate these group actions and their duality in musical examples by Pachelbel, Wagner, and Ives.

We will mathematically explain this duality in more detail later, but we give a short description now. First, we recall that the *centralizer* of a subgroup  $H$  in a group  $G$  is the set of elements of  $G$  which commute with all elements of  $H$ , namely

$$C_G(H) = \{g \in G \mid gh = hg \text{ for all } h \in H\}.$$

The centralizer of  $H$  is itself a subgroup of  $G$ . We also recall that an action of a group  $K$  on a set  $S$  can be equivalently described as a homomorphism from  $K$  into the symmetric group<sup>5</sup>  $\text{Sym}(S)$  on the set  $S$ . Thus, each of our two group actions of the dihedral group above gives rise to a homomorphism into the symmetric group on the set  $S$  of major and minor triads. It turns out that each of these homomorphisms is an embedding, so that we have two distinguished copies,  $H_1$  and  $H_2$ , of the dihedral group of order 24 in  $\text{Sym}(S)$ . One of these copies is generated by  $P$ ,  $L$ , and  $R$ . With these notions in place, we can now express David Lewin's idea of duality in [17]: the two group actions are *dual* in the sense that each of these subgroups  $H_1$  and  $H_2$  of  $\text{Sym}(S)$  is the centralizer of the other!

Practically no musical background is required to enjoy this discussion since we provide mathematical descriptions of the required musical notions, beginning with the traditional translation of pitch classes into elements of  $\mathbb{Z}_{12}$  via Figure 1. From there we develop a musical model using group actions and topology. We hope that this article will resonate with mathematical and musical readers alike.

**2. PITCH CLASSES AND INTEGERS MODULO 12.** As the ancient Greeks noticed, any two pitches that differ by a whole number of octaves<sup>6</sup> sound alike. Thus we

<sup>4</sup>The interpretation of the *Ninth Symphony* excerpt as a path on the torus was proposed by Cohn in [6].

<sup>5</sup>The *symmetric group* on a set  $S$  consists of all bijections from  $S$  to  $S$ . The group operation is function composition.

<sup>6</sup>A pitch  $y$  is an octave above a pitch  $x$  if the frequency of  $y$  is twice that of  $x$ .

identify any two such pitches, and speak of *pitch classes* arising from this equivalence relation. Like most modern music theorists, we use equal tempered tuning, so that the octave is divided into twelve pitch classes as follows.

A	A♯ B♭	B	C	C♯ D♭	D	D♯ E♭	E	F	F♯ G♭	G	G♯ A♭	A
---	----------	---	---	----------	---	----------	---	---	----------	---	----------	---

The interval between two consecutive pitch classes is called a *half-step* or *semitone*. The notation ♯ means to move up a semitone, while the notation ♭ means to move down a semitone. Note that some pitches have two letter names. This is an instance of *enharmonic equivalence*.

Music theorists have found it useful to translate *pitch classes* to *integers modulo 12* taking 0 to be C as in Figure 1. Mod 12 addition and subtraction can be read off of this clock; for example  $2 + 3 = 5 \pmod{12}$ ,  $11 + 4 = 3 \pmod{12}$ , and  $1 - 4 = 9 \pmod{12}$ . We can also determine the musical interval from one pitch class to another; for example, the interval from D to G♯ is six semitones. This description of pitch classes in terms of  $\mathbb{Z}_{12}$  can be found in many articles, such as [18] and [20]. This translation from pitch classes to integers modulo 12 permits us to easily use abstract algebra for modeling musical events, as we shall see in the next two sections.

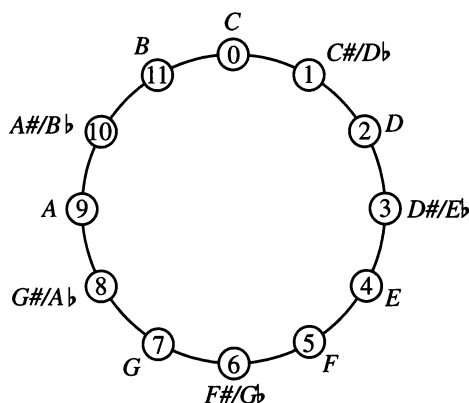

Figure 1. The musical clock.

**3. TRANSPOSITION AND INVERSION.** Throughout the ages, composers have drawn on the musical tools of transposition and inversion. For example, we may consider a type of musical composition popular in the 18th century that is especially associated with J. S. Bach: the *fugue*. Such a composition contains a principal melody known as the *subject*; as the fugue progresses, the subject typically will recur in transposed and inverted forms. Mathematically speaking, *transposition* by an integer  $n \pmod{12}$  is the function

$$T_n : \mathbb{Z}_{12} \longrightarrow \mathbb{Z}_{12}$$

$$T_n(x) := x + n \pmod{12}$$

and *inversion*<sup>7</sup> about  $n$  is the function

$$I_n : \mathbb{Z}_{12} \longrightarrow \mathbb{Z}_{12}$$

$$I_n(x) := -x + n \pmod{12}.$$

Bach often used diatonic transposition and inversion, which we can view as mod 7 transposition and inversion after identifying the diatonic scale with  $\mathbb{Z}_7$ . However, many contemporary composers intensively use mod 12 transposition and inversion; see for example [11], [19], and [20].

As is well known, these transpositions and inversions have a particularly nice representation in terms of the musical clock in Figure 1. The transposition  $T_1$  corresponds to clockwise *rotation* of the clock by  $\frac{1}{12}$  of a turn, while  $I_0$  corresponds to a *reflection* of the clock about the 0-6 axis. Hence  $T_1$  and  $I_0$  generate the *dihedral group* of symmetries of the 12-gon. Since  $(T_1)^n = T_n$  and  $T_n \circ I_0 = I_n$ , we see that the 12 transpositions and 12 inversions form the dihedral group of order 24. The relations

$$T_m \circ T_n = T_{m+n \pmod{12}}$$

$$T_m \circ I_n = I_{m+n \pmod{12}}$$

$$I_m \circ T_n = I_{m-n \pmod{12}}$$

$$I_m \circ I_n = T_{m-n \pmod{12}}$$

are easy to verify. This group is often called the *T/I-group*. The first action of the dihedral group of order 24 on the set of major and minor triads that we study is defined via the *T/I-group*.

**4. MAJOR AND MINOR TRIADS.** Triadic harmony has been in use for hundreds of years and is still used every day in popular music. In this section we use the integers modulo 12 to define major and minor triads; in this way we can consider them as objects upon which the dihedral group of order 24 may act.

A *triad* consists of three simultaneously played notes. A *major triad* consists of a *root* note, a second note 4 semitones above the root, and a third note 7 semitones above the root. For example, the *C-major triad* consists of  $\{0, 4, 7\} = \{C, E, G\}$  and is represented as a chord polygon in Figure 2. See [18] for beautiful illustrations of the utility of chord polygons. Since any major triad is a subset of the pitch-class space  $\mathbb{Z}_{12}$ , and transpositions and inversions act on  $\mathbb{Z}_{12}$ , we can also apply transpositions and inversions to any major triad. Figure 2 shows what happens when we apply  $I_0$  to the *C-major triad*. The resulting triad is *not* a major triad, but instead a *minor triad*.

A *minor triad* consists of a *root* note, a second note 3 semitones above the root, and a third note 7 semitones above the root. For example, the *f-minor triad* consists of  $\{5, 8, 0\} = \{F, Ab, C\}$  and its chord polygon appears in Figure 2.

Altogether, the major and minor triads form the set  $S$  of *consonant triads*, which are called *consonant* because of their smooth sound. A consonant triad is named after its root. For example, the *C-major triad* consists of  $\{0, 4, 7\} = \{C, E, G\}$  and the *f-minor triad* consists of  $\{5, 8, 0\} = \{F, Ab, C\}$ . Musicians commonly denote major triads by upper-case letters and minor triads by lower-case letters as indicated in the table of all consonant triads in Figure 3.

<sup>7</sup>At this point in our discussion, musically experienced readers may notice that the word *inversion* has several meanings in music theory. The kind of inversion we define here is different from *chord inversion* in which pitches other than the root are placed in the bass. This latter kind of inversion accounts for terms such as *first-inversion triad*. Our discussion is not concerned with chord inversion.

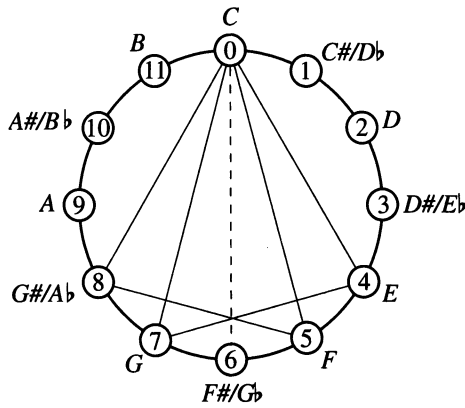

Figure 2.  $I_0$  applied to a  $C$ -major triad yields an  $f$ -minor triad.

Major Triads	Minor Triads
$C = \langle 0, 4, 7 \rangle$	$\langle 0, 8, 5 \rangle = f$
$C\sharp = D\flat = \langle 1, 5, 8 \rangle$	$\langle 1, 9, 6 \rangle = f\sharp = g\flat$
$D = \langle 2, 6, 9 \rangle$	$\langle 2, 10, 7 \rangle = g$
$D\sharp = E\flat = \langle 3, 7, 10 \rangle$	$\langle 3, 11, 8 \rangle = g\sharp = a\flat$
$E = \langle 4, 8, 11 \rangle$	$\langle 4, 0, 9 \rangle = a$
$F = \langle 5, 9, 0 \rangle$	$\langle 5, 1, 10 \rangle = a\sharp = b\flat$
$F\sharp = G\flat = \langle 6, 10, 1 \rangle$	$\langle 6, 2, 11 \rangle = b$
$G = \langle 7, 11, 2 \rangle$	$\langle 7, 3, 0 \rangle = c$
$G\sharp = A\flat = \langle 8, 0, 3 \rangle$	$\langle 8, 4, 1 \rangle = c\sharp = d\flat$
$A = \langle 9, 1, 4 \rangle$	$\langle 9, 5, 2 \rangle = d$
$A\sharp = B\flat = \langle 10, 2, 5 \rangle$	$\langle 10, 6, 3 \rangle = d\sharp = e\flat$
$B = \langle 11, 3, 6 \rangle$	$\langle 11, 7, 4 \rangle = e$

Figure 3. The set  $S$  of consonant triads.

This table has several features. Angular brackets denote ordered sets, which are called *pitch-class segments* in the music literature. Since we are speaking of simultaneously sounding notes, it is not necessary to insist on a particular ordering of the elements within the brackets.<sup>8</sup> However the mathematical artifice of an ordering will simplify the discussion of the  $PLR$ -group and duality that we are approaching. Such subtleties are discussed in [10].

The table also reflects the componentwise action of the  $T/I$ -group because of this ordering. In the table, an application of  $T_1$  to an entry gives the entry immediately below it, for example

$$\begin{aligned} T_1\langle 0, 4, 7 \rangle &= \langle T_1(0), T_1(4), T_1(7) \rangle \\ &= \langle 1, 5, 8 \rangle. \end{aligned}$$

More generally, if we count the first entry as entry 0, the  $n$ th entry in the first column is

$$T_n\langle 0, 4, 7 \rangle = \langle T_n(0), T_n(4), T_n(7) \rangle \quad (1)$$

<sup>8</sup>Another reason not to insist on the ordering is the fact that the pitch-class set  $\{0, 4, 7\}$  is neither transpositionally nor inversionally symmetrical.

and the  $n$ th entry in the second column is

$$I_n(0, 4, 7) = \langle I_n(0), I_n(4), I_n(7) \rangle. \quad (2)$$

From the table we conclude that the action of the  $T/I$ -group is *simply transitive*, that is, for any consonant triads  $Y$  and  $Z$  there is a unique element  $g$  of the  $T/I$ -group such that  $gY = Z$ . As we have just seen in equations (1) and (2), for any  $Y$  and  $Z$  there exist  $g_1$  and  $g_2$  such that  $g_1C = Z$  and  $g_2C = Y$ , and thus  $gY = Z$  for  $g = g_1g_2^{-1}$ . A quick verification also shows that  $g$  is unique.

We can see the uniqueness of  $g$  in a more elegant way using the orbit-stabilizer theorem. The *orbit* of an element  $Y$  of a set  $S$  under a group action of  $G$  on  $S$  consists of all those elements of  $S$  to which  $Y$  is moved, in other words

$$\text{orbit of } Y = \{hY \mid h \in G\}.$$

The *stabilizer group* of  $Y$  consists of all those elements of  $G$  which fix  $Y$ , namely

$$G_Y = \{h \in G \mid hY = Y\}.$$

**Theorem 4.1 (Orbit-Stabilizer Theorem).** *If a finite group  $G$  acts on a set  $S$  and  $G_Y$  denotes the stabilizer group of  $Y \in S$ , then*

$$|G|/|G_Y| = |\text{orbit of } Y|.$$

In our situation,  $G$  is the dihedral group of order 24,  $S$  is the set of consonant triads as in Figure 3, and  $|\text{orbit of } Y| = 24$ , so that  $|G_Y| = 1$ . Thus, if  $g'Y = gY$  then  $g^{-1}g'Y = Y$ , so that  $g^{-1}g'$  is the identity element of the group, and finally  $g' = g$ .

Generally, a group action of  $G$  on a set  $S$  is the same as a homomorphism from  $G$  into the symmetric group on the set  $S$ . Indeed, from a group action we obtain such a homomorphism by

$$g \mapsto (Y \mapsto gY).$$

In the case of the  $T/I$ -group, this homomorphism is given by the componentwise action of the  $T/I$ -group and it is injective. For simplicity we identify the  $T/I$ -group with its image in the symmetric group on the set  $S$ .

**5. THE *PLR*-GROUP.** Up to this point, we have studied the action of the dihedral group of order 24 on the set  $S$  of major and minor triads via transposition and inversion. Next we discuss a second musical action of the dihedral group, but this time defined in terms of the *PLR*-group.

Late 19th-century chromatic music, such as the music of Wagner, has triadic elements to it but is not entirely tonal. For this reason, it has been called “triadic post-tonal” in texts such as [5]. Recognizing that this repertoire has features which are beyond the reach of traditional tonal theory, some music theorists have worked on developing an alternative theory.

*Neo-Riemannian theory*, initiated by David Lewin in [16] and [17], has taken up the study of *PLR*-transformations to address analytical problems raised by this repertoire. We next define the *PLR*-group as the subgroup of the symmetric group on the set  $S$  generated by the bijections  $P$ ,  $L$ , and  $R$ . As it turns out, this subgroup is isomorphic to the dihedral group of order 24, as we prove in Theorem 5.1. The *PLR*-group has a

beautiful geometric depiction in terms of a tiling on the torus called the *Tonnetz* (Figure 5), which we also describe. A famous example from Beethoven's *Ninth Symphony* is a path in the dual graph (Figures 6 and 7).

Consider the three functions  $P, L, R : S \rightarrow S$  defined by

$$P\langle y_1, y_2, y_3 \rangle = I_{y_1+y_3}\langle y_1, y_2, y_3 \rangle \quad (3)$$

$$L\langle y_1, y_2, y_3 \rangle = I_{y_2+y_3}\langle y_1, y_2, y_3 \rangle \quad (4)$$

$$R\langle y_1, y_2, y_3 \rangle = I_{y_1+y_2}\langle y_1, y_2, y_3 \rangle. \quad (5)$$

These are called *parallel*, *leading tone exchange*, and *relative*. These are *contextual inversions* because the axis of inversion depends on the aggregate input triad. Notably, the functions  $P, L$ , and  $R$  are *not* defined componentwise, and this distinguishes them from inversions of the form  $I_n$ , where the axis of inversion is independent of the input triad. For  $P, L$ , and  $R$  the axis of inversion on the musical clock when applied to  $\langle y_1, y_2, y_3 \rangle$  is indicated in the table below.

Function	Axis of Inversion Spanned by
$P$	$\frac{y_1+y_3}{2}, \frac{y_1+y_3}{2} + 6$
$L$	$\frac{y_2+y_3}{2}, \frac{y_2+y_3}{2} + 6$
$R$	$\frac{y_1+y_2}{2}, \frac{y_1+y_2}{2} + 6$

See Figure 4 for the axes of inversion in the application of  $P, L$ , and  $R$  to the  $C$ -major triad.

If we consider major and minor as a *parity*, then there is a particularly nice verbal description of  $P, L$ , and  $R$ . The function  $P$  takes a consonant triad to that unique consonant triad of opposite parity which has the first component and third component switched. Thus, as unordered sets, the input and output triads overlap in two notes. For example,  $P\langle 0, 4, 7 \rangle = \langle 7, 3, 0 \rangle$  and  $P\langle 7, 3, 0 \rangle = \langle 0, 4, 7 \rangle$ . A musician will notice that  $P$  applied to  $C$  is  $c$ , while  $P$  applied to  $c$  is  $C$ . In general,  $P$  takes a major triad to its parallel minor and a minor triad to its parallel major. A major triad and a minor triad are said to be *parallel* if they have the same letter name but are of opposite parity. The function  $P$  is manifestly an involution.

The other two functions,  $L$  and  $R$ , similarly have maximally overlapping inputs and outputs and are involutions. The function  $L$  takes a consonant triad to that unique consonant triad of opposite parity which has the second component and third component switched; for example  $L\langle 0, 4, 7 \rangle = \langle 11, 7, 4 \rangle$  and  $L\langle 11, 7, 4 \rangle = \langle 0, 4, 7 \rangle$ . The function  $R$  takes a consonant triad to that unique consonant triad of opposite parity which has the first component and second component switched; for example  $R\langle 0, 4, 7 \rangle = \langle 4, 0, 9 \rangle$  and  $R\langle 4, 0, 9 \rangle = \langle 0, 4, 7 \rangle$ . A musician will notice that  $R$  applied to  $C$  is  $a$  and  $R$  applied to  $a$  is  $C$ . In general,  $R$  takes a major triad to its relative minor and a minor triad to its relative major. A major triad and a minor triad are said to be *relative* if the root of the minor triad is three semitones below the root of major triad. The functions  $R$  and  $L$  are also involutions.

Each of the three functions corresponds to ubiquitous musical motions that are easy to learn to recognize by ear. That the input and output overlap in two common tones is one reason the motions are easily recognized. These three triadic transformations were employed by European composers with great success in the years 1500–1900. Another distinguishing feature is the minimal motion of the moving voice. For example, in the application of these three functions to the  $C$ -major triad above, we see in the case of

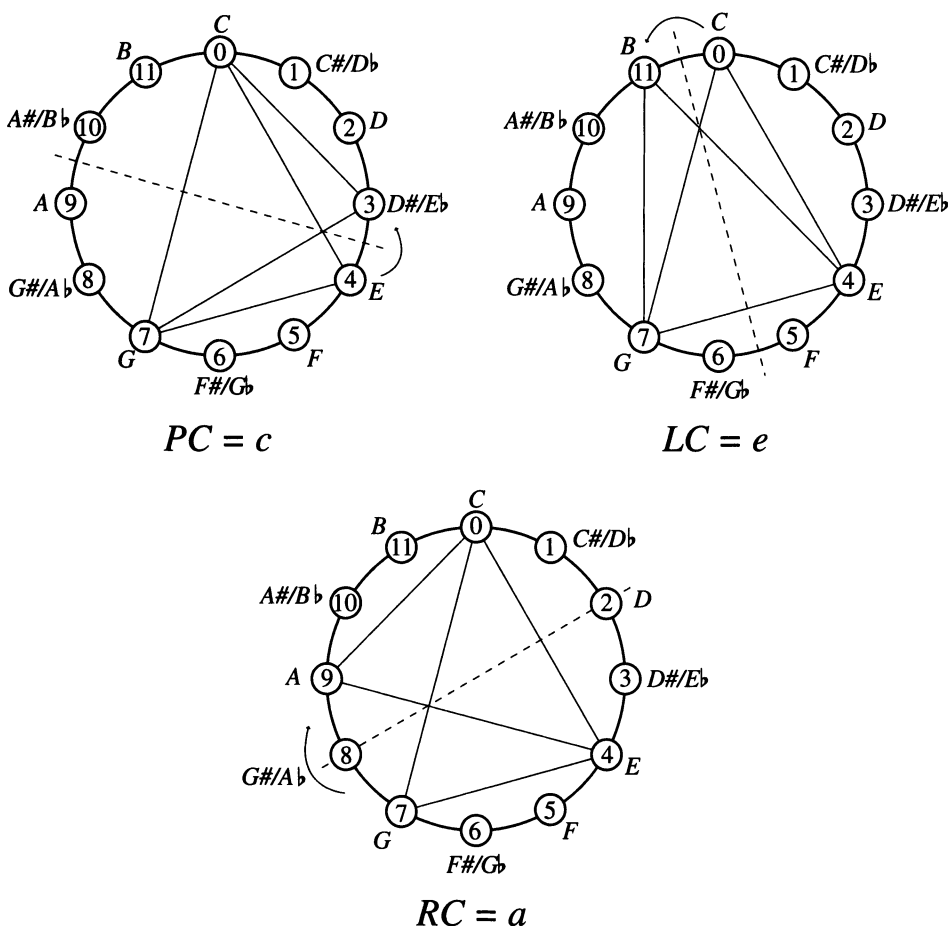

**Figure 4.** Minimal motion of the moving voice under  $P$ ,  $L$ , and  $R$ .

$P$  that 4 moves to 3, in the case of  $L$  that 0 moves to 11, and in the case of  $R$  that 7 moves to 9. This is illustrated in Figure 4.

This *parsimonious voice leading* is unique to the major and minor triads as shown in [6]: if one starts with any other three-note chord, such as  $\langle 0, 1, 3 \rangle$  for example, and generates 24 chords by transposition and inversion, then the analogues of  $P$ ,  $L$ , and  $R$  will always have large jumps in their moving voices.<sup>9</sup> As Cohn points out in [6], the potential for parsimonious voice leading is totally independent of the acoustic properties of consonant triads; instead it is “a function of their group-theoretic properties as equally tempered entities modulo 12.”

The group generated by  $P$ ,  $L$ , and  $R$  is called the *PLR-group* or the *neo-Riemannian group* after the late 19th-century music theorist Hugo Riemann. Its structure is well known, as we illustrate in the following theorem. An important ingredient for our proof is a famous chord progression in Beethoven’s *Ninth Symphony*. Cohn observed this chord progression in [6].

**Theorem 5.1.** *The PLR-group is generated by  $L$  and  $R$  and is dihedral of order 24.*

<sup>9</sup>If one starts with  $\langle 0, 4, 8 \rangle$ , then  $P$ ,  $L$ , and  $R$  will be trivial, so we exclude this case.

*Proof.* First we remark that one can use formulas (3), (4), and (5) to show that  $PT_1 = T_1P$ ,  $LT_1 = T_1L$ , and  $RT_1 = T_1R$ .

If we begin with the  $C$ -major triad and alternately apply  $R$  and  $L$ , then we obtain the following sequence of triads.<sup>10</sup>

$$C, a, F, d, Bb, g, Eb, c, Ab, f, Db, bb, Gb, eb, B, g\sharp, E, c\sharp, A, f\sharp, D, b, G, e, C$$

This tells us that the 24 bijections  $R, LR, RLR, \dots, R(LR)^{11}$ , and  $(LR)^{12} = 1$  are distinct, that the  $PLR$ -group has at least 24 elements, and that  $LR$  has order 12. Further  $R(LR)^3(C) = c$ , and since  $R(LR)^3$  has order 2 and commutes with  $T_1$ , we see that  $R(LR)^3 = P$ , and the  $PLR$ -group is generated by  $L$  and  $R$  alone.

If we set  $s = LR$  and  $t = L$ , then  $s^{12} = 1$ ,  $t^2 = 1$ , and

$$\begin{aligned} tst &= L(LR)L \\ &= RL \\ &= s^{-1}. \end{aligned}$$

It only remains to show that the  $PLR$ -group has order 24, and then it will be dihedral as on page 68 of [23]. We postpone the proof of this last fact until Theorem 6.1. ■

**Corollary 5.2.** *The  $PLR$ -group acts simply transitively on the set of consonant triads.*

*Proof.* From the chord progression in Theorem 5.1 we see that the orbit of  $C$ -major is all of  $S$ , and has 24 elements. As the  $PLR$ -group also has 24 elements, simple transitivity follows from the orbit-stabilizer theorem. ■

The Oettingen/Riemann *Tonnetz* in Figure 5 is a beautiful geometric depiction of the  $PLR$ -group. The word *Tonnetz* is German for “tone network” and is sometimes translated as the “table of tonal relations.” The vertices of this graph are pitch classes, while each of the triangles is a major or minor triad. The graph extends infinitely in all directions, though we have only drawn a finite portion. On the horizontal axis we have the circle of fifths, and on the diagonal axes we have the circles of major and minor thirds.<sup>11</sup> Since these circles repeat, we see that the *Tonnetz* is doubly periodic. Therefore we obtain a torus by gluing the top and bottom edges as well as the left and right edges of a fundamental domain, which is a certain subregion of the one indicated in Figure 5. The functions  $P$ ,  $L$ , and  $R$  allow us to navigate the *Tonnetz* by flipping a triangle about an edge whose vertices are the preserved pitch classes. This is investigated in [6] for scales of arbitrary chromatic number.

The Oettingen/Riemann *Tonnetz* in Figure 5 is similar to the one in Figure 2 on page 172 of [5].<sup>12</sup> Figure 5 is an *interpretation* of Riemann’s *Tonnetz*, which resulted from the work of many neo-Riemannian theorists, especially [4], [15], and [16].<sup>13</sup>

<sup>10</sup>We recall that upper-case letters refer to major triads and lower-case letters refer to minor triads.

<sup>11</sup>The intervallic torus for minor thirds described in Table 2 of [18] is contained in a diagonal of the *Tonnetz*.

<sup>12</sup>Our Figure 5 does not exactly reproduce Figure 2 of [5], but introduces the following changes: pitch-class numbers are shown rather than letter note names, the  $D$  arrow is deleted, and a different region of the *Tonnetz* is displayed. Special thanks go to Richard Cohn for giving us permission to use this modified version of the figure.

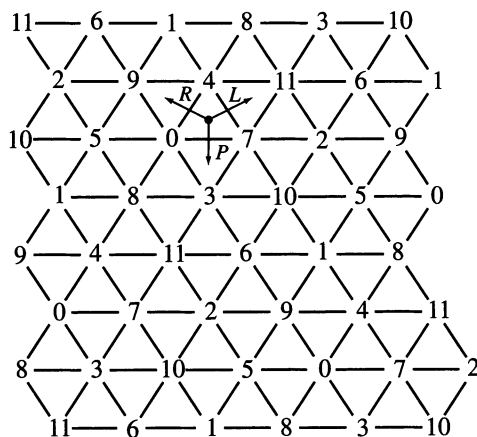

Figure 5. The Oettingen/Riemann *Tonnetz*.

Enharmonic equivalence and equal-tempered tuning are crucial for this modern interpretation. Since Riemann did not use enharmonic equivalence nor equal tempered tuning, his original *Tonnetz* was not periodic and did not lie on a torus. The original *Tonnetz* can be found on page 20 of [21], or on page 102 of the translation [22] (annotated in [25]).

Douthett and Steinbach have associated the graph in Figure 6 to the neo-Riemannian *PLR*-group in [8].<sup>14</sup> This time the vertices are the consonant triads, and there is an edge between two vertices labelled by *P*, *L*, or *R* whenever *P*, *L*, or *R* sends one vertex to the other. This graph is also periodic vertically and horizontally, so the top and bottom edges can be glued together, and the left and right edges can also be glued after twisting a third of the way. The result is a graph on the torus. Earlier, Waller studied this graph on the torus in [24], and observed that its automorphism group is the dihedral group of order 24. Waller’s torus is pictured in Figure 7.<sup>15</sup> Douthett and Steinbach also make

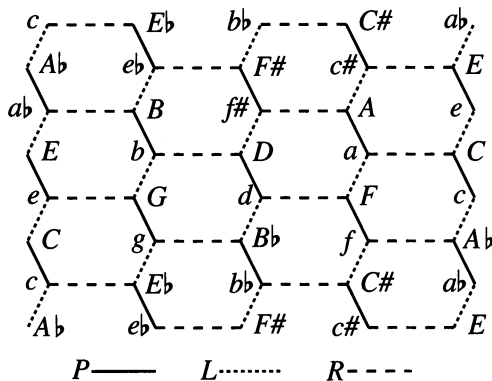

Figure 6. Douthett and Steinbach’s graph from [8].

<sup>13</sup>The article [15] contains the first appearance of the group generated by *P*, *L*, *R*, and *D*, where  $D = T_5$  is the *dominant* transformation. This group appears again in [13] as the group  $\mathcal{H}$  on page 98. Interestingly,  $D = LR$  on major triads, but  $D = RL$  on minor triads.

<sup>14</sup>Figure 6 has been reproduced by kind permission of the authors.

<sup>15</sup>Waller’s torus from [24] has been reproduced in Figure 7 by kind permission of the U.K. Mathematical Association and the *Mathematical Gazette*.

this observation in [8], and present Waller's torus in the context of neo-Riemannian theory.

Movement in music can be likened to movement along the surface of the torus. The sequence of consonant triads in the proof of Theorem 5.1 traces out a regular path on the torus in Figure 7, and the first 19 triads of that sequence occur in order in measures 143–176 of the second movement of Beethoven's *Ninth Symphony*! Cohn observed this remarkable sequence in [4], [6], and [7].

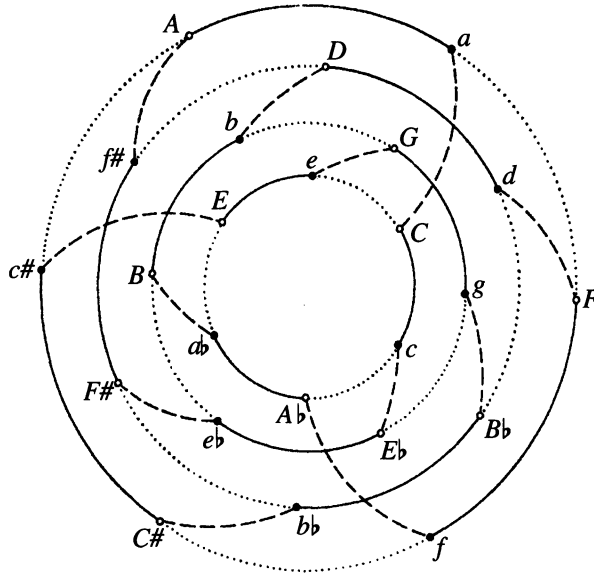

Figure 7. Waller's torus from [24].

There is a relationship between the two graphs and their tori: they are *dual graphs*. That means if you draw a vertex in the center of every hexagonal face of Figure 6 or 7, and connect two vertices by an edge whenever the corresponding faces have a common edge, then you get the *Tonnetz*. In fact, a vertex of the *Tonnetz* is the unique note in the intersection of the triads on the corresponding face; e.g., 0 is the intersection of  $a$ ,  $C$ ,  $c$ ,  $A\flat$ ,  $f$ , and  $F$ .

But in the musical model we are considering, these graphs are not the only things which are dual. Using the notion of centralizer, we will show that the  $T/I$ -group and the  $PLR$ -group are dual groups!

**6.  $T/I$  AND  $PLR$  ARE DUAL.** As we have seen, the dihedral group of order 24 acts on the set  $S$  of major and minor triads simply transitively in two interesting ways: (i) through the  $T/I$ -group using transposition and inversion, and (ii) through the neo-Riemannian  $PLR$ -group using the  $P$ ,  $L$ , and  $R$  functions. If we consider the  $T/I$ -group and the  $PLR$ -group as subgroups of the symmetric group  $\text{Sym}(S)$  on the set  $S$ , then an interesting relation occurs: the centralizer of the  $T/I$ -group is the  $PLR$ -group and the centralizer of the  $PLR$ -group is the  $T/I$ -group! This means the  $T/I$ -group and the  $PLR$ -group are *dual groups* in the terminology of Lewin [17]. We prove this

momentarily. This duality in the sense of Lewin has also been studied on pages 110–111 of [13], and also in [14].<sup>16</sup>

The term “dualism” in the neo-Riemannian literature, such as [13] and [14], is used mostly to refer to a different idea associated with the music theorist Hugo Riemann. Specifically, Riemannian “dualism” refers to a property of *individual* elements of the *PLR*-group. A precise definition can be found on page 59 of [13]: “This property—whatever a transformation does to a major triad, its effect on a minor triad is precisely the opposite—may be regarded as an explicit representation of Riemann’s harmonic dualism.”

As an illustration of the duality between the *T/I*-group and the *PLR*-group in the sense of Lewin, we can compute with the *C*-major triad. If we apply  $T_1$  to the *C*-major triad, and then  $L$ , that is the same as first applying  $L$  and then applying  $T_1$  (see Figure 8). A category theorist would say that the diagram

$$\begin{array}{ccc}
 S & \xrightarrow{T_1} & S \\
 L \downarrow & & \downarrow L \\
 S & \xrightarrow{T_1} & S
 \end{array}$$

*commutes*, i.e., the result is the same no matter which path one takes. Similarly, one can use formulas (3), (4), and (5) to show that  $P$ ,  $L$ , and  $R$  commute with  $T_1$  and  $I_0$ . Since these are the generators of the respective groups, we conclude that any diagram with vertical arrows in the *PLR*-group and horizontal arrows in the *T/I*-group, as in Figure 8, will commute.

<sup>16</sup>In [13] and [14], Hook embedded the neo-Riemannian *PLR*-group into the group  $\mathcal{U}$  of uniform triadic transformations. In the following explanation of this embedding into Hook’s group, we use  $S$  to denote the set of consonant triads, as in most of the present article. A *uniform triadic transformation*  $U$  is a function  $U : S \rightarrow S$  of the form  $(\sigma, t^+, t^-)$  where  $\sigma \in \{+, -\}$ , and  $t^+, t^- \in \mathbb{Z}_{12}$ . The sign  $\sigma$  indicates whether  $U$  preserves or reverses parity (major vs. minor), the component  $t^+$  indicates by how many semitones  $U$  transposes the root of a major triad, and the component  $t^-$  indicates by how many semitones  $U$  transposes the root of a minor triad. For example, the neo-Riemannian operation  $R$  is written as  $(-, 9, 3)$ , meaning that  $R$  maps any major triad to a minor triad whose root is 9 semitones higher, and  $R$  maps any minor triad to a major triad whose root is 3 semitones higher, as one sees with  $R(C) = a$  and  $R(a) = C$ . Other familiar elements in  $\mathcal{U}$  are  $P = (-, 0, 0)$ ,  $L = (-, 4, 8)$ ,  $R = (-, 9, 3)$ , and  $T_n = (+, n, n)$ . Uniform triadic transformations are automatically invertible, like all these examples. The non-Riemannian operations  $D = T_5$  and  $M = (-, 9, 8)$ , called *dominant* and *diatonic mediant* respectively, are also contained in  $\mathcal{U}$ . Thus, the group  $\mathcal{U}$  of uniform triadic transformations is a good place to study how Riemannian operations and non-Riemannian operations interact. However, the inversions  $I_n$  are *not* in  $\mathcal{U}$ . The uniform triadic transformations *and* inversions are contained in the group  $\mathcal{Q}$  of *quasi uniform triadic transformations*. This group is much larger:  $|\mathcal{Q}| = 1152$  while  $|\mathcal{U}| = 288$ .

Hook defined on page 110 of [13] a *duality operator* on  $\mathcal{Q}$  which restricts to an anti-isomorphism between the *T/I*-group and the *PLR*-group; transpositions and inversions are mapped to *Schritte* and *Wechsel* respectively. Moreover, the Lewinnian duality we study in this paper between *T/I* and *PLR* in  $\text{Sym}(S)$  restricts to the subgroup  $\mathcal{Q}$  of  $\text{Sym}(S)$ : the centralizer of the *T/I*-group in  $\mathcal{Q}$  is precisely the *PLR*-group and the centralizer of the *PLR*-group in  $\mathcal{Q}$  is precisely the *T/I*-group. Interestingly, the centralizer of the transposition group in  $\mathcal{Q}$  is  $\mathcal{U}$ . Even better, the centralizer of the transposition group in  $\text{Sym}(S)$  is exactly  $\mathcal{U}$  by Theorem 1.7 of [13]. The group  $\mathcal{U}$  is isomorphic to the wreath product  $\mathbb{Z}_{12} \wr \mathbb{Z}_2$ .

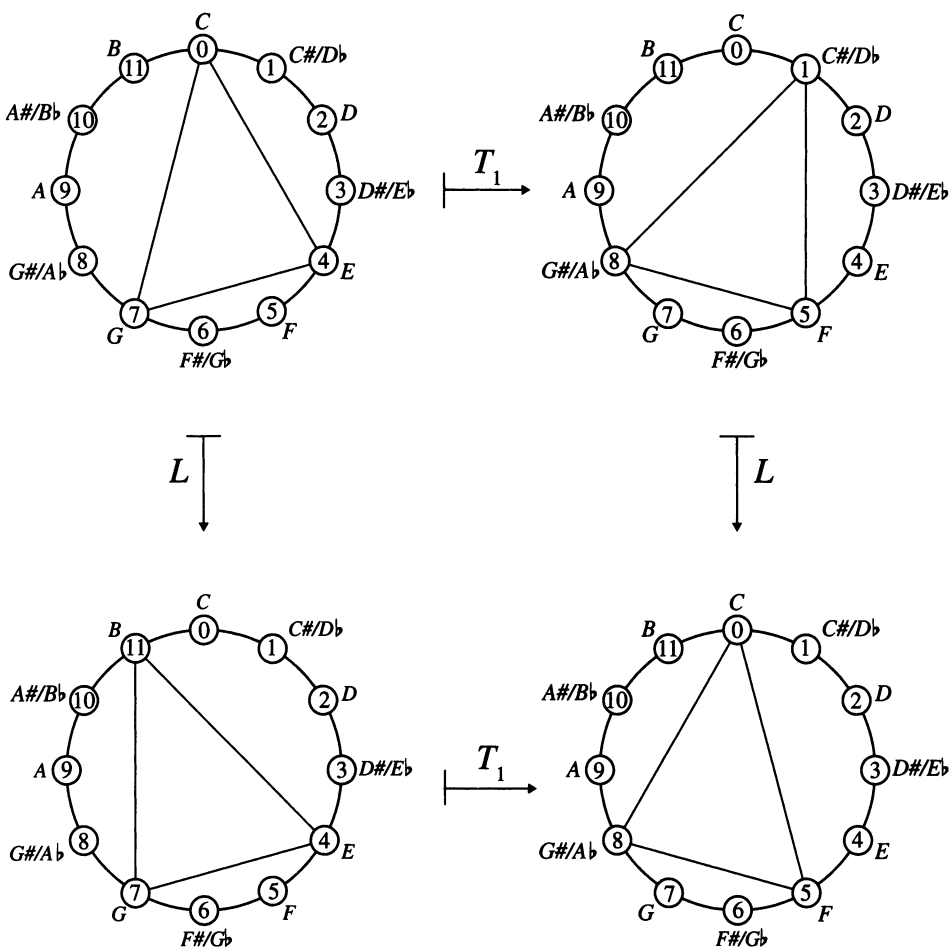

Figure 8. Illustration of commutativity of  $T_1$  and  $L$ .

**Theorem 6.1.** *The PLR-group and the  $T/I$ -group are dual. That is, each acts simply transitively on the set  $S$  of major and minor triads, and each is the centralizer of the other in the symmetric group  $\text{Sym}(S)$ .*

*Proof.* In Section 4 we already concluded that the  $T/I$ -group acts simply transitively on the set of major and minor triads from Figure 3 and equations (1) and (2). We also determined in the discussion just before the statement of the current theorem that any element of the  $PLR$ -group commutes with any element of the  $T/I$ -group. In other words, the  $PLR$ -group is contained in the centralizer  $C(T/I)$  of the  $T/I$ -group in  $\text{Sym}(S)$ .

For any element  $Y$  of  $S$  we claim that the stabilizer of  $Y$  under the action of  $C(T/I)$  contains only the identity element. Suppose that  $h$  is in  $C(T/I)$  and fixes  $Y$ , and that  $g$  is in the  $T/I$ -group. Then we have

$$\begin{aligned} hY &= Y \\ ghY &= gY \\ hgY &= gY. \end{aligned}$$

Since the  $T/I$ -group acts simply transitively, every  $Y'$  in  $S$  is of the form  $gY$  for some  $g$  in the  $T/I$ -group, and therefore  $h$  is the identity function on  $S$  by the last equation above. Thus the stabilizer  $C(T/I)_Y$  of  $Y$  in  $C(T/I)$  is the trivial group.

An application of the orbit-stabilizer theorem to  $G = C(T/I)$  gives us

$$|C(T/I)|/|C(T/I)_Y| = |\text{orbit of } Y| \leq |S| = 24.$$

As the  $PLR$ -group is a subgroup of  $C(T/I)$  and  $|C(T/I)_Y| = 1$ , we conclude

$$|PLR\text{-group}| \leq |C(T/I)| \leq 24.$$

From the famous chord progression of Beethoven's *Ninth Symphony* in the first part of Theorem 5.1, we know that the  $PLR$ -group has at least 24 elements. Thus, the  $PLR$ -group has exactly 24 elements and is equal to  $C(T/I)$ . This completes the proof of Theorem 5.1, so we may now conclude as in Corollary 5.2 that the  $PLR$ -group acts simply transitively on  $S$ .

It only remains to show that the  $T/I$ -group is the centralizer of the  $PLR$ -group. However, this follows by reversing the roles of the  $T/I$ -group and the  $PLR$ -group in the orbit-stabilizer argument we just made. ■

Now that we have met an important example of dual groups, one may ask if there are other examples as well and how they arise. Dual groups have indeed been known for over 100 years, and can arise in only one way, as the following theorem specifies.

**Theorem 6.2 (Cayley).** *If  $G$  is a group, then we obtain dual groups via the two embeddings of  $G$  into  $\text{Sym}(G)$  as left and right actions of  $G$  on itself. All dual groups arise in this way.*<sup>17</sup>

We now present three musical examples of the duality between the  $T/I$ -group and the  $PLR$ -group. Our first example is Johann Pachelbel's famous Canon in  $D$ , composed circa 1680 and reproduced in Figure 9. The chord progression in the associated commutative diagram occurs in 28 variations in the piece.

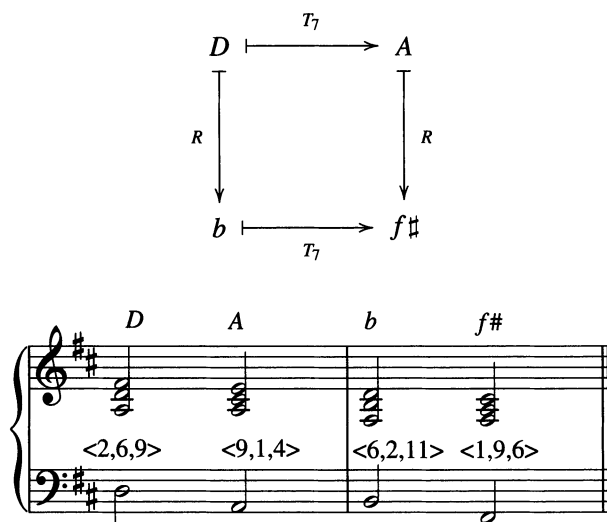

Figure 9. Chord progression from Pachelbel, Canon in  $D$ .

<sup>17</sup>We thank László Babai for reminding us of this classical theorem.

Another example can be found in the “Grail” theme of the Prelude to Parsifal, Act 1, an opera completed by Richard Wagner in 1882. See Figure 10 and the following commutative diagram.

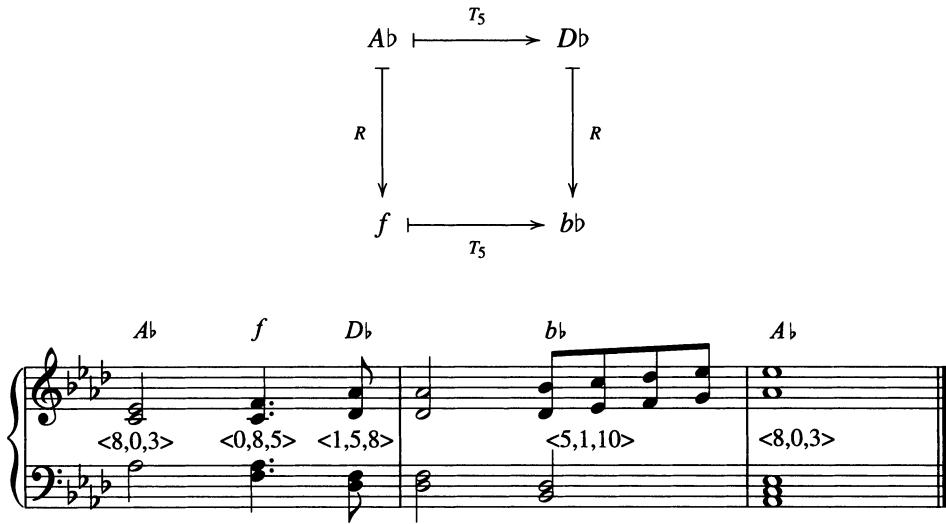

Figure 10. Wagner, *Parsifal*, “Grail” Theme.

A particularly interesting example is in the opening measure of “Religion,” a song for voice and piano written by Charles Ives in the 1920s. This time the horizontal transformation is an inversion, namely  $I_6$ . Since the inversion  $I_6$  transforms major triads to minor triads, we have  $LR$  acting upon triads of different parity. This allows us to observe that  $LR$  transforms  $D$ -major *up* by 5 semitones, but at the same time transforms  $a$ -minor *down* by 5 semitones. This makes the behavior of the left column *dual* (in the sense of Riemann) to the behavior of the right column.

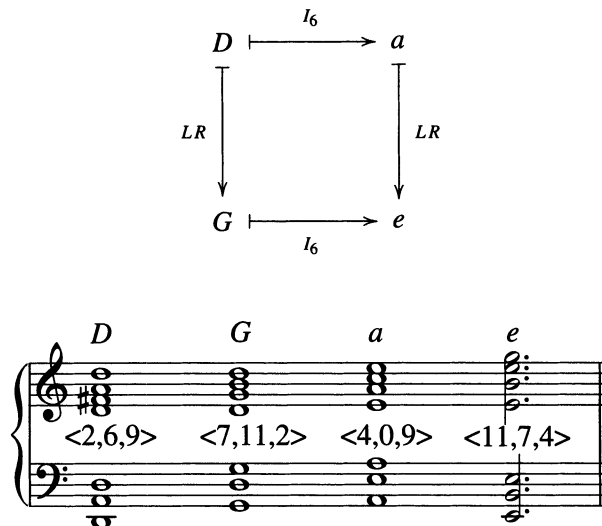

Figure 11. Ives, “Religion”.

**7. RECAPITULATION AND VARIATION.** In summary, the dihedral group of order 24 acts on the set of major and minor triads in two ways: through the  $T/I$ -group and through the  $PLR$ -group. Further, these two actions are dual. The  $PLR$ -group has two interesting geometric depictions: the *Tonnetz* and Waller's torus. But why stop at major and minor triads? One could just as well study the analogues of  $P$ ,  $L$ , and  $R$  in the context of dominant seventh chords and half-diminished seventh chords. Indeed, that has been pursued in [3] and [12]. Moreover, the theory can be generalized further; the authors of [10] studied a neo-Riemannian group for arbitrary pitch-class segments in terms of contextual inversion, and applied their findings to an analysis of Hindemith, *Ludus Tonalis*, Fugue in *E*. Neo-Riemannian groups for asymmetrical pitch-class segments were studied in [13] and [14] from a root-interval point of view.

There are many avenues of exploration for undergraduates. Students can listen to group actions in action and apply the orbit-stabilizer theorem to works of music.

By experimenting with the  $PLR$ -group, students can also learn about generators and relations for groups. The torus for Beethoven's *Ninth Symphony* is an inviting way to introduce students to topology. More tips for undergraduate study can be found on the website [9], which contains lecture notes, problems for students, slides, and more examples. For both advanced readers and students, the website [2] includes entertaining discussion and interesting posts by musicians and mathematicians alike.

**ACKNOWLEDGMENTS.** Thomas M. Fiore was supported at the University of Chicago by NSF Grant DMS-0501208. At the Universitat Autònoma de Barcelona he was supported by Grant SB2006-0085 of the Programa Nacional de ayudas para la movilidad de profesores de universidad e investigadores españoles y extranjeros. Thomas M. Fiore and Alissa S. Crans both thank Peter May for his ongoing support and encouragement. Thomas M. Fiore thanks Karen Rhea at the University of Michigan for offering him the opportunity to try this material in the classroom. He also thanks the students of Math 107 at the University of Michigan and the VIGRE REU students at the University of Chicago who eagerly explored these ideas in class and on their own. The authors also thank Blake Mellor for assistance on the figures, and Michael Orrison for comments on an earlier draft.

## REFERENCES

1. M. Babbitt, Twelve-tone invariants as compositional determinants, *The Musical Quarterly* **46** (1960) 246–259.
2. J. Baez, This week's finds in mathematical physics (Week 234) (2006), available at <http://math.ucr.edu/home/baez/week234.html>.
3. A. Childs, Moving beyond neo-Riemannian triads: Exploring a transformational model for seventh chords, *Journal of Music Theory* **42** (1998) 181–194.
4. R. Cohn, Dramatization of hypermetric conflicts in the Scherzo of Beethoven's Ninth Symphony, *19th-Century Music* **15** (1992) 22–40.
5. ———, Introduction to neo-Riemannian theory: A survey and a historical perspective, *Journal of Music Theory* **42** (1998) 167–180.
6. ———, Neo-Riemannian operations, parsimonious trichords, and their *Tonnetz* representations, *Journal of Music Theory* **41** (1997) 1–66.
7. ———, Properties and generability of transpositionally invariant sets, *Journal of Music Theory* **35** (1991) 1–32.
8. J. Douthett and P. Steinbach, Parsimonious graphs: A study in parsimony, contextual transformations, and modes of limited transposition, *Journal of Music Theory* **42** (1998) 241–263.
9. T. M. Fiore, 2007 Chicago REU lectures on mathematical music theory, available at <http://www.math.uchicago.edu/~fiore/>.
10. T. M. Fiore and R. Satyendra, Generalized contextual groups, *Music Theory Online* **11** (2005); available at <http://mto.societymusictheory.org>.
11. A. Forte, *The Structure of Atonal Music*, Yale University Press, New Haven, 1977.
12. E. Gollin, Some aspects of three-dimensional *Tonnetze*, *Journal of Music Theory* **42** (1998) 195–206.
13. J. Hook, Uniform triadic transformations, *Journal of Music Theory* **46** (2002) 57–126.

14. ———, Uniform Triadic Transformations, Ph.D. dissertation, Indiana University, Bloomington, IN, 2002.
15. B. Hyer, Reimag(in)ing Riemann, *Journal of Music Theory* **39** (1995) 101–138.
16. D. Lewin, A formal theory of generalized tonal functions, *Journal of Music Theory* **26** (1982) 32–60.
17. ———, *Generalized Musical Intervals and Transformations*, Yale University Press, New Haven, 1987.
18. B. J. McCartin, Prelude to musical geometry, *College Math. J.* **29** (1998) 354–370.
19. R. Morris, *Composition with Pitch-Classes: A Theory of Compositional Design*, Yale University Press, New Haven, 1988.
20. J. Rahn, *Basic Atonal Theory*, Schirmer, New York, 1980.
21. H. Riemann, Ideen zu einer ‘Lehre von den Tonvorstellungen’, *Jahrbuch der Musikbibliothek Peters* **21/22** (1914/15) 1–26.
22. ———, Ideas for a study “on the imagination of tone” (trans. R. W. Wason and E. W. Marvin), *Journal of Music Theory* **36** (1992) 81–117.
23. J. J. Rotman, *An Introduction to the Theory of Groups*, 4th ed., Graduate Texts in Mathematics, vol. 148, Springer-Verlag, New York, 1995.
24. D. Waller, Some combinatorial aspects of the musical chords, *The Mathematical Gazette* **62** (1978) 12–15.
25. R. W. Wason and E. W. Marvin, Riemann’s “Ideen zu einer ‘Lehre von den Tonvorstellungen’”: An annotated translation, *Journal of Music Theory* **36** (1992) 69–79.

**ALISSA S. CRANS** earned her B.S. in Mathematics from the University of Redlands and her Ph.D. in Mathematics from the University of California at Riverside under the guidance of John Baez. She is currently an Assistant Professor of Mathematics at Loyola Marymount University and has taught at Pomona College, the Ohio State University, and the University of Chicago. Along with Naomi Cameron and Kendra Killpatrick, Alissa organizes the Pacific Coast Undergraduate Mathematics Conference. In addition to mathematics, she enjoys playing the clarinet with the LA Winds, running, biking, reading, and traveling.  
*Department of Mathematics, Loyola Marymount University, One LMU Drive, Suite 2700, Los Angeles, CA 90045*  
*acrans@lmu.edu*

**THOMAS M. FIORE** received a B.S. in Mathematics and a B.Phil. in German at the University of Pittsburgh. He completed his Ph.D. in Mathematics at the University of Michigan in 2005 under the direction of Igor Kriz. He is an N.S.F. Postdoctoral Fellow and Dickson Instructor at the University of Chicago, and was a Profesor Visitante at the Universitat Autònoma de Barcelona during 2007-08. His research interests include algebraic topology, higher category theory, and mathematical music theory.  
*Department of Mathematics, University of Chicago, Chicago, IL 60637, and*  
*Departament de Matemàtiques, Universitat Autònoma de Barcelona, 08193 Bellaterra (Barcelona), Spain*  
*fiore@math.uchicago.edu*

**RAMON SATYENDRA** received his Ph.D. from the University of Chicago in the History and Theory of Music. He is currently an Associate Professor of Music Theory at the University of Michigan and is on the editorial boards of *Intégral* and the *Journal of Mathematics and Music*.  
*School of Music, Theatre and Dance, University of Michigan, E.V. Moore Building, 1100 Baitz Dr., Ann Arbor, MI 48109-2085*  
*ramsat@umich.edu*